

THERMOSEALER

millseal+
manual



OPERATING MANUAL

REVISIONS

The following table lists subsequent editions/revisions of the manual.
The "Description" field brief explains the subject of the latest revision

| Code | Rev. | Date | Description |
|----------|------|---------|-----------------|
| 97050483 | 4 | 12-2017 | Text adaptation |

TABLE OF CONTENTS

ENGLISH (TRANSLATION FROM THE ORIGINAL IN ITALIAN).





| | |
|---|-----------|
| 1. INTRODUCTION | 3 |
| 1.1. APPLICABLE EUROPEAN DIRECTIVES | 3 |
| 1.2. INTENDED USE..... | 3 |
| 1.3. PURPOSE OF THE MANUAL..... | 4 |
| 1.4. GENERAL WARNINGS..... | 4 |
| 2. CONTENTS OF THE PACKAGE | 5 |
| 2.1. DIMENSIONS AND WEIGHT..... | 5 |
| 2.2. DESCRIPTION OF THE ITEMS..... | 5 |
| 3. PRODUCT PRESENTATION | 6 |
| 3.1. MAIN PERFORMANCES..... | 6 |
| 3.2. VIEWS (WITH DIMENSIONS) | 7 |
| 4. INSTALLATION | 8 |
| 4.1. GENERAL PRECAUTIONS | 8 |
| 4.2. ELECTRICAL CONNECTION | 8 |
| 4.3. PRODUCT PREPARATION | 8 |
| 4.4. PAPER ROLL INSTALLATION | 11 |
| 5. OPERATION | 12 |
| 5.1. PREPARATION..... | 12 |
| 5.2. PAPER INSERTION..... | 12 |
| 5.3. WELDING AN END AND CUTTING | 13 |
| 5.4. BAG RETURN AND FINISHING | 14 |
| 6. PREPARING THE MATERIAL TO BE SEALED | 15 |
| 6.1. MOVING THE MATERIAL..... | 15 |
| 6.2. CLEANING THE TOOLS..... | 15 |
| 6.3. WRAPPED MATERIAL | 15 |
| APPENDIX A TECHNICAL CHARACTERISTICS | 16 |
| SUMMARY TABLE | 16 |
| SAFETY DEVICES..... | 16 |
| APPENDIX C - MANTEINANCE | 17 |
| GENERALS..... | 17 |
| CLEANING | 17 |
| BLADES REPLACEMENT | 17 |
| FUSES REPLACEMENT | 17 |
| APPENDIX D - TROUBLESHOOTING | 18 |

1. INTRODUCTION





Dear Customer,

thank you for choosing this product. We hope it will perform to your full satisfaction. This manual describes all procedures for the correct installation and use of the equipment. Should you have any questions or suggestions concerning this product or our support, do not hesitate to contact us.

Note, warning and danger symbols used through the manual

| | |
|---|---|
|  | NOTE PAY SPECIAL ATTENTION; NOTES FOR PROPER INSTALLATION AND MAINTENANCE PROCEDURES AND USE METHODS. |
|  | WARNING THIS SYMBOL INDICATES A POTENTIAL DANGER OF INJURY. FOLLOW THE PROCEDURES DESCRIBED IN THE MANUAL TO AVOID INJURING THE USER AND/O |
|  | DANGER THIS SYMBOL SIGNALS A POSSIBLE DANGER FOR PEOPLE. FOLLOW THE SUGGESTED PROCEDURE IN ORDER TO PREVENT POSSIBLE DAMAGE TO USERS AND/OR OTHERS. |
|  | DANGER POTENTIAL HAZARD DUE TO HIGH TEMPERATURE. |

Symbols on equipment

| | |
|---|---|
|  | Potential hazard due to high temperature. |
|  | Equipment in accordance with applicable directives. |
|  | Waste disposal in accordance with Directive 2012/19/UE. |
|  | Consult the user manual |



1.1. APPLICABLE EUROPEAN DIRECTIVES

The product described in this manual has been constructed to the highest safety standards and does not pose any hazard for the operator if used according to the instructions. The product complies with the following applicable European Directives:

- 2014/35/CE
- 2014/30/CE
- 2011/65/UE (Rohs II)

1.2. INTENDED USE

The unit is meant for professional use and can only be employed for the purpose it was designed for, that is the thermo-sealing and cutting of sterilization paper/polypropylene rolls.

| | |
|---|--|
|  | NOTE THE UNIT CANNOT WORK WITH ROLLS OF A MATERIAL OTHER THAN THE ONES STATED ABOVE. |
|  | WARNING THE DEVICE MUST ONLY BE USED BY QUALIFIED PERSONNEL. IT MAY NOT BE USED OR HANDLED BY INEXPERT AND/OR UNAUTHORIZED PERSONNEL FOR ANY REASON. |

1.3. PURPOSE OF THE MANUAL

| | |
|---|---|
|  | NOTES |
| | THE INFORMATION IN THIS MANUAL IS SUBJECT TO CHANGE WITHOUT NOTICE. |
| | THE MANUFACTURER IS NOT RESPONSIBLE FOR DIRECT, INDIRECT, ACCIDENTAL OR CONSEQUENTIAL DAMAGES OR ANY OTHER DAMAGES RELATING TO THE PROVISION/USE OF THIS INFORMATION. |
| | NO PART OF THIS DOCUMENT MAY BE REPRODUCED, ADAPTED OR TRANSLATED IN ANY FORM OR BY ANY MEANS WITHOUT THE PRIOR WRITTEN PERMISSION OF THE MANUFACTURER. |
| | FOR CORRECT INTERPRETATION OF THE INSTRUCTIONS CONTAINED IN THIS MANUAL, THE ITALIAN VERSION SHALL BE VALID AS ORIGINAL TEXT. |

The manual purpose is to provide instructions for:

- General knowledge of the product;
- Correct installation;
- Its safe and efficient use
- The treatment of tools and/or materials to submit to sterilization.

More the appendix includes:

- The technical features of the product;
- Maintenance operations;
- Troubleshooting and solutions;
- Other documentation.

1.4. GENERAL WARNINGS

The product must always be used according to the procedures included in this manual and never for purposes other than the ones indicated.

| | |
|--|--|
|  | WARNING |
| | THE USER IS RESPONSIBLE FOR ALL LEGAL REQUIREMENTS RELATED TO THE INSTALLATION AND USE OF THIS PRODUCT. THE MANUFACTURER WILL NOT BE RESPONSIBLE FOR ANY BREAKAGE, MALFUNCTIONS, PROPERTY DAMAGE OR INJURY IN THE EVENT THAT THE PRODUCT IS NOT INSTALLED OR USED CORRECTLY. |

Please observe the following precautions in order to avoid injury or property damage; in particular:

- Use **ONLY** recommended cleaning detergents.
- **Do not** pour water or other liquids or inflammable products on the equipment.
- **Do not** use the equipment in the presence of gas or explosive or inflammable vapors.

| | |
|---|--|
|  | DANGER |
| | BEFORE CARRYING OUT ANY MAINTENANCE OPERATION, ALWAYS DISCONNECT THE POWER CABLE PLUG FROM THE POWER SOCKET. |

- Make sure the electrical system is grounded conforming to current laws and/or standards;
- **Do not** remove any label or nameplate from the device; request new ones, if necessary.
- Use **only original replacement parts**.

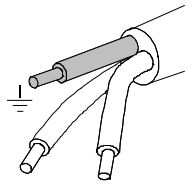

| | |
|---|---|
|  | WARNING |
| | THE FAILURE TO OBSERVE THE ABOVE, RELEASES THE MANUFACTURER FROM ALL LIABILITY. |

2. CONTENTS OF THE PACKAGE

2.1. DIMENSIONS AND WEIGHT

 **NOTE**
CHECK THE INTEGRITY OF THE PACKAGE UPON RECEIPT.

Once the package is opened, check that:

- the supply matches the specifications of the order (see the accompanying document);
- that there is no obvious product damage.

| Size and weight | MILLSEAL PLUS |
|-----------------|---------------|
| Height | 260 mm |
| Width | 600 mm |
| Depth | 300 mm |
| Overall weight | 6 kg |

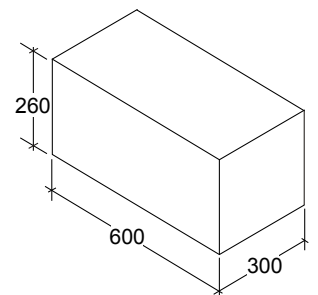

 **NOTE**
IN THE CASE OF A WRONG PRODUCT, MISSING PARTS OR ANY TYPE OF DAMAGE, IMMEDIATELY PROVIDE A DETAILED DESCRIPTION TO THE RESELLER AND THE TRANSPORTER THAT MADE THE DELIVERY.

 **NOTE**
KEEP THE ORIGINAL PACKAGING AND USE IT WHENEVER THE DEVICE IS TO BE TRANSPORTED. THE USE OF DIFFERENT PACKAGING COULD DAMAGE THE PRODUCT DURING SHIPMENT.

2.2. DESCRIPTION OF THE ITEMS

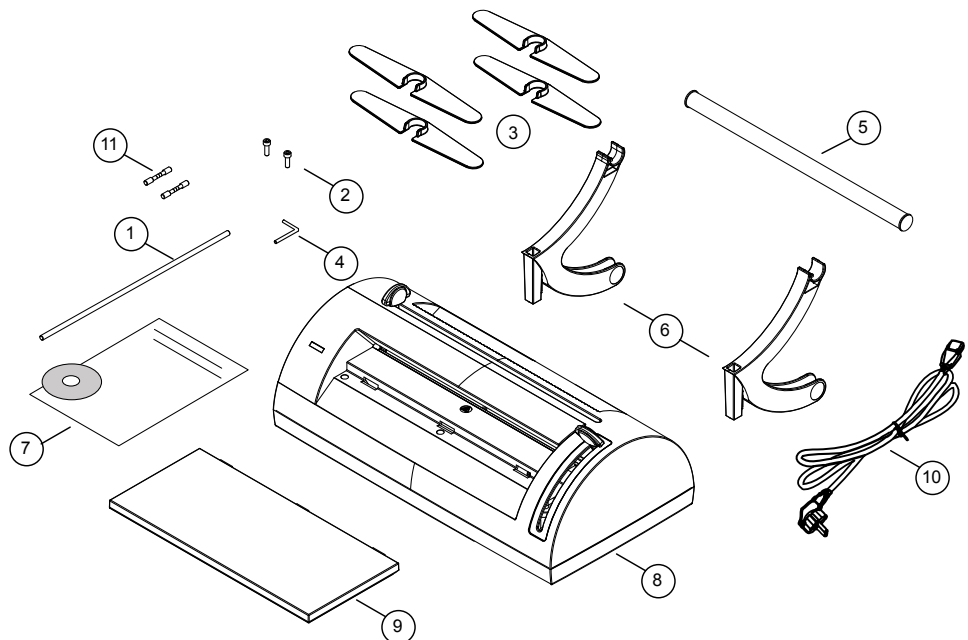

- 1 Paper-stop barrier
- 2 2 screws
- 3 4 aiming devices
- 4 Allen wrench
- 5 Roll holder tube
- 6 2 roll supports
- 7 Operator documentation
- 8 Millseal Plus Thermo-sealing machine
- 9 Table area
- 10 Power lead
- 11 2 fuses

 **NOTE**
THE CUSTOMER MUST KEEP THE WARRANTY CERTIFICATE TOGETHER WITH THE RECEIPT.

3. PRODUCT PRESENTATION

3.1. MAIN PERFORMANCES

Millseal Plus is the thermo-sealing machine which fits as a natural complement to the range of steam sterilisers.

It is an elegantly, space-saving designed piece of equipment that is both user-friendly and reliability, even with heavy use.

Millseal Plus is therefore a useful option for all those users who require professional equipment with an excellent ratio of quality to price and performance.

Millseal Plus is an electronically controlled thermo-sealer with a sealing band of 12 mm fit to resist the sterilization processes of the modern sterilizers featuring fractioned pre-vacuum, and to assure in time the sterility of the packages.

Efficient heat control in the welding area is achieved thanks to the automatic temperature adjustment, ensuring high and constant performance.

The solid structure in plastic and aluminium and the ergonomic and minimalist shape help to maintain a high level of hygiene, weight and overall size and excellent stability during use. All this with the objective of offering a product suited to the daily needs in the medical area.

| | |
|---|--|
|  | <p style="text-align: center;">NOTE</p> <p>FOR THE DESCRIPTION OF THE SECURITY DEVICES, REFER TO APPENDIX A (TECHNICAL CHARACTERISTICS)</p> |
|---|--|

For a good operation of the thermo-sealer the first and essential task is its correct installation; in this way possible malfunctions or damages to the unit will be avoided.

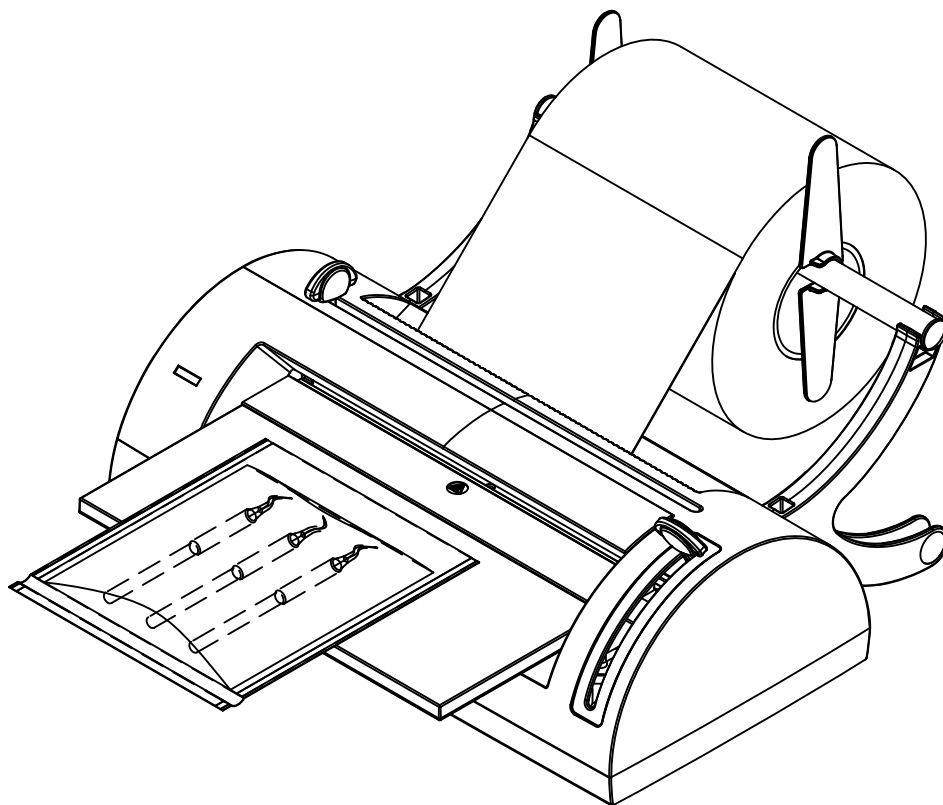

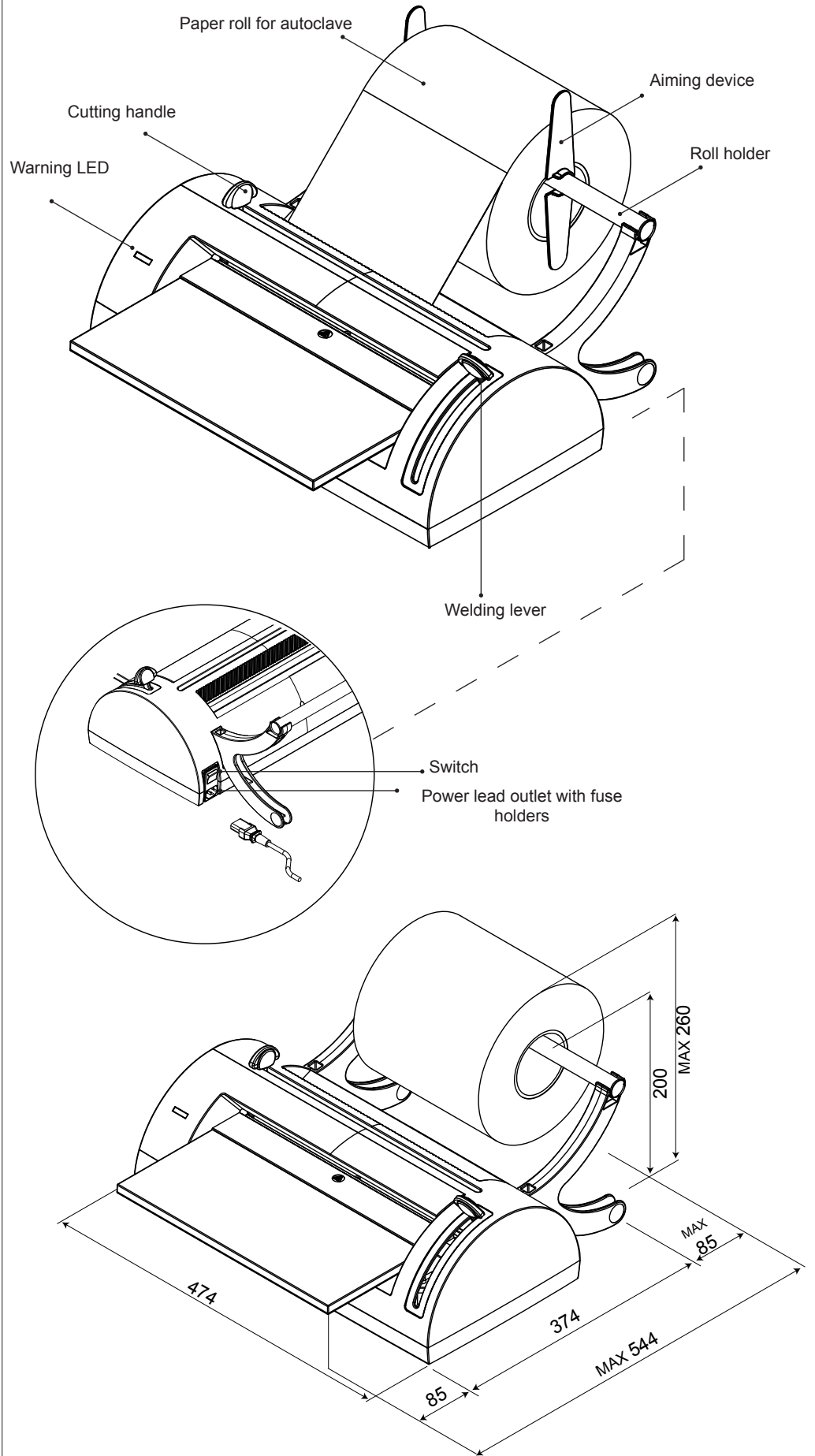

3.2 VIEWS (WITH DIMENSIONS)



4. INSTALLATION

Therefore please read carefully the notes and warnings reported in the rest of this chapter.

| | |
|---|--|
|  | NOTE THE TECHNICAL SERVICE IS AT YOUR DISPOSAL, TO CLEAR ANY QUESTIONS OR PROVIDE FURTHER INFORMATION. |
|---|--|

| | |
|---|---|
|  | ATTENTION THE ELECTRICAL INSTALLATION MUST BE PROVIDED WITH EARTH CONNECTION. |
|---|---|

4.1. GENERAL PRECAUTIONS

- Install the thermo-sealer on a flat surface, leaving enough room for its operation and adequate ventilation.
- Makes sure that the resting plane is strong enough to support the unit and roll weight (max 15 kg);
- Do not install near sinks to avoid contact with water or liquids that could cause short circuits or situations potentially dangerous for the operator;
- Do not install in humid or poorly ventilated environments;
- Do not install in environment with the presence of inflammable and/o explosive **gas** or **steams**;
- Install the unit so that the power supply cable is not bent or pressed along its route up to the mains socket.

4.2. ELECTRICAL CONNECTION

In compliance with the standing regulations, the unit must be connected to a mains socket of the electrical installation with power rating suitable for the unit consumption and provided with earth connection. The socket must be suitably protected upstream by a terminal board provided with electro thermal magnetic switch and differential switch.

Connect the supplied power cable to the mains socket on the rear of the equipment.

| | |
|---|--|
|  | NOTE ONLY USE THE POWER SUPPLY CABLE PROVIDED WITH THE UNIT; POSSIBLE PLUG REPLACEMENT IS UNDER THE FULL RESPONSIBILITY OF THE USER. DIRECTLY CONNECT THE POWER SUPPLY CABLE TO THE SOCKET. DO NOT USE EXTENSIONS, ADAPTERS OR OTHER ACCESSORIES. |
|---|--|

4.3. PRODUCT PREPARATION

1. Carefully remove the package contents.
2. Insert the roller supports (A) in the appropriate holders.
Tighten the two screws (B) with the provided Allen wrench (C)

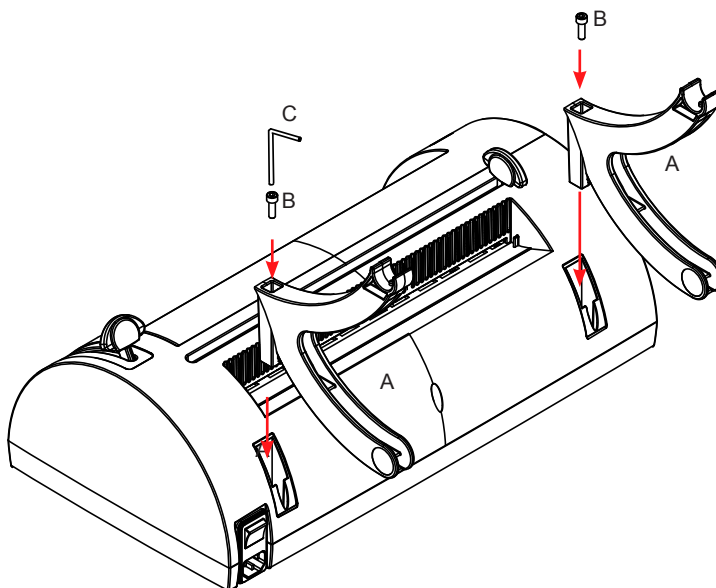

3. Insert the roll holder tube (D) in the supports (A), checking that the holes at the end of the tube properly engage in the teeth (E) present on the supports (A).

Rest the paper stop barrier (F) in the compatible holders (G).

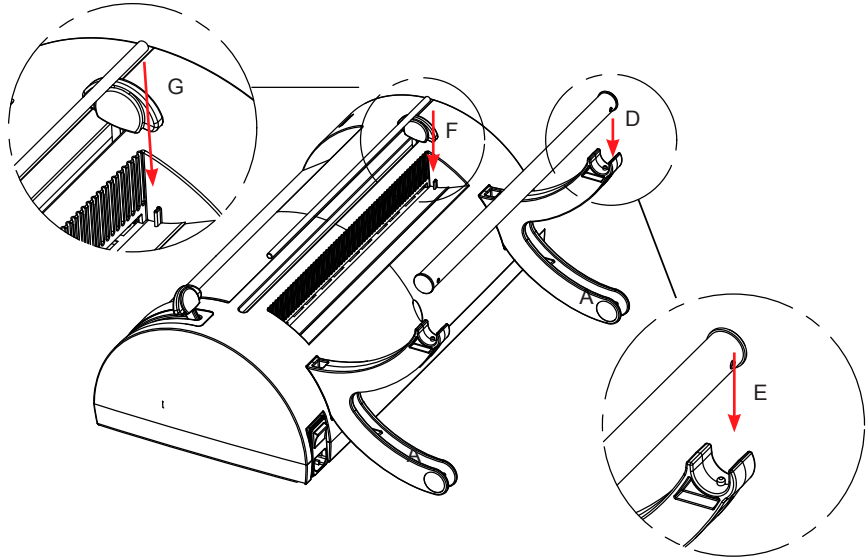

4. Insert the table area (H) in the appropriate slots (I).

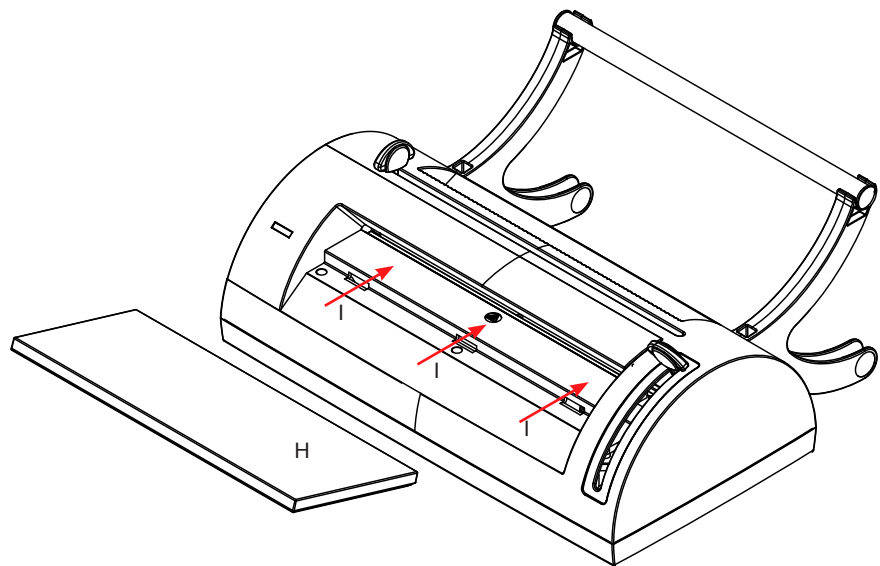

5. Connect the power lead (J).

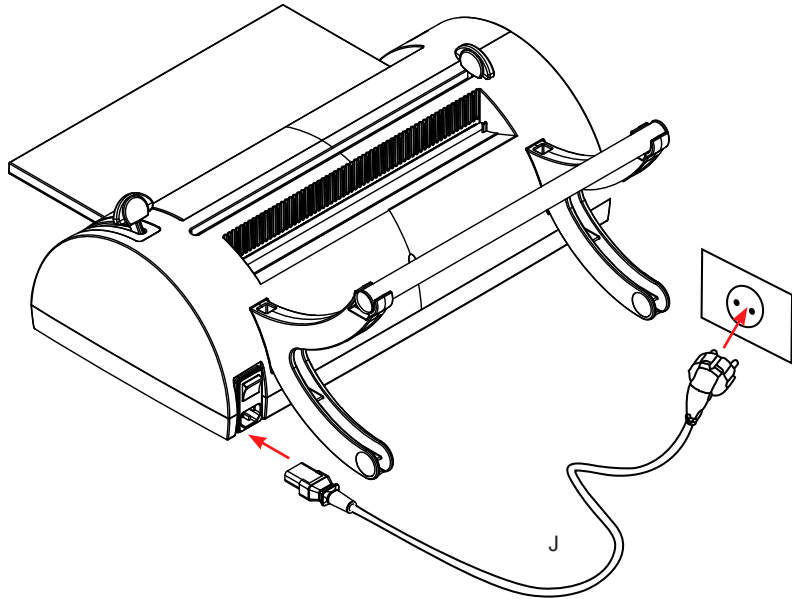

| | |
|---|---|
|  | <p>NOTE POSITION THE MACHINE IN SUCH A WAY THAT THE ENDS OF THE CABLE ARE EASILY ACCESSIBLE.</p> |
|---|---|

6. The thermo-sealing machine is now ready for use.

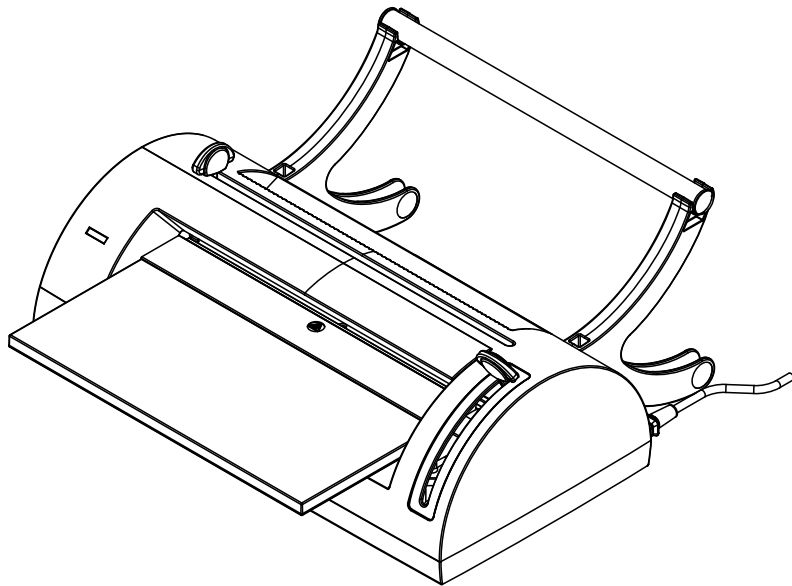

4.4. PAPER ROLL INSTALLATION

- Insert the paper roll on the roll holder tube.
- Install the roll holder/roll unit on the arm holders (as described in the previous paragraph), positioned in such a way that the paper belt unrolls downward and with the polypropylene film in view, taking care to have the sheet pass under the paper-stop barrier.
- Finally, fasten the aiming devices.

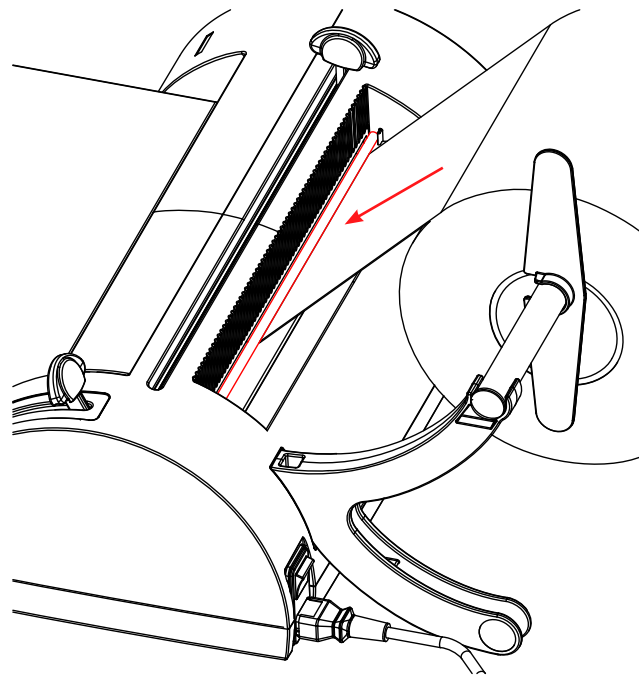
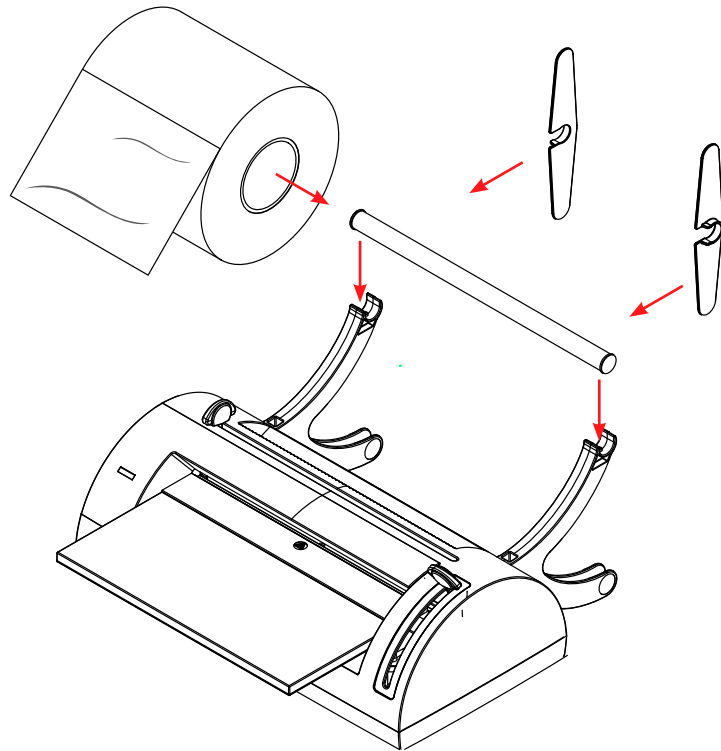

5. OPERATION

5.1. PREPARATION

- Verify that the welding lever (B) is positioned at the highest end of the guide. Switch on the machine via the switch (A) located on the rear part.
- The frontal green LED (C) will flash.
- Heating resistance is powered and the **temperature** will increase gradually. When the ideal level for proper welding is reached, the frontal **green LED** will remain fixed **on**, emitting an acoustic signal.

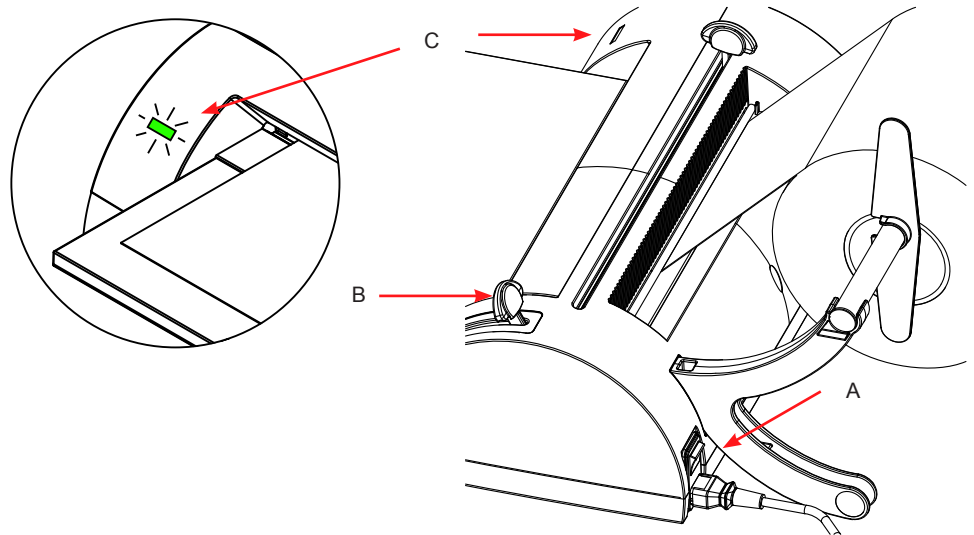

5.2. PAPER INSERTION

- Have the paper belt pass under the paper-stop barrier and insert it in the rear slot. Then remove it from the front to the desired length. (see paragraph 5.3)
- It is best to pull the paper out to a length equal to that of the tool plus 8 cm to allow proper welding of the edge.

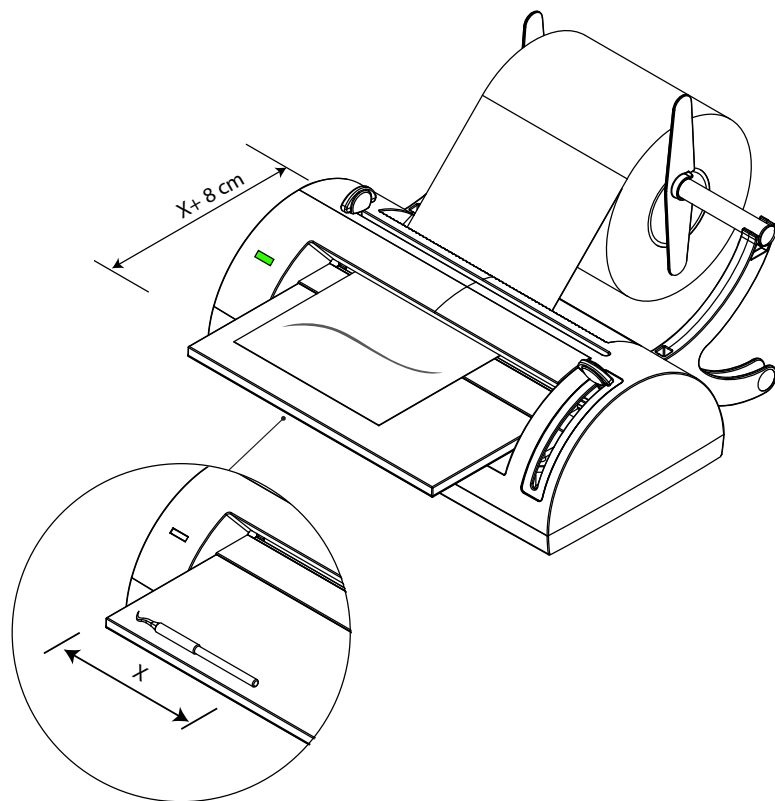

NOTE
BAGS SHORTER THAN 7 CM ARE NOT RECOMMENDED.

5.3. WELDING AN END AND CUTTING

- Lower the lever (B) from position 1 to position 2. The green LED (C) will flash quickly until welding has finished, indicated by an acoustic signal
- Slide the cutting lever (D) to the opposite end.

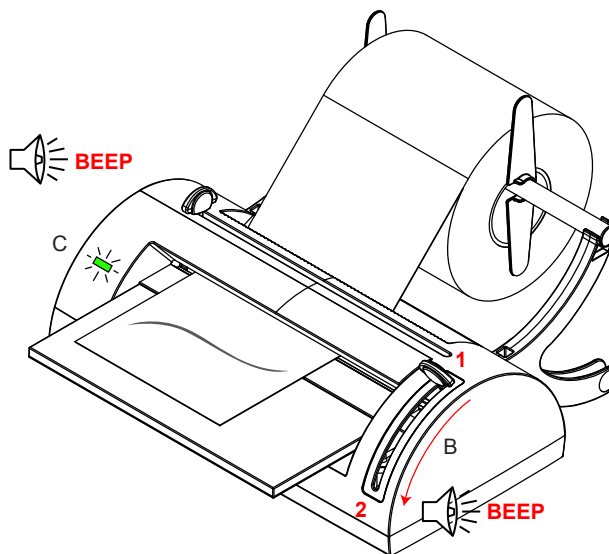

- Lift the lever (B) from position 2 to the original position 1.
- The frontal LED will return to a fixed green once again, and the acoustic signal will switch off. The bag is now sealed on one end.

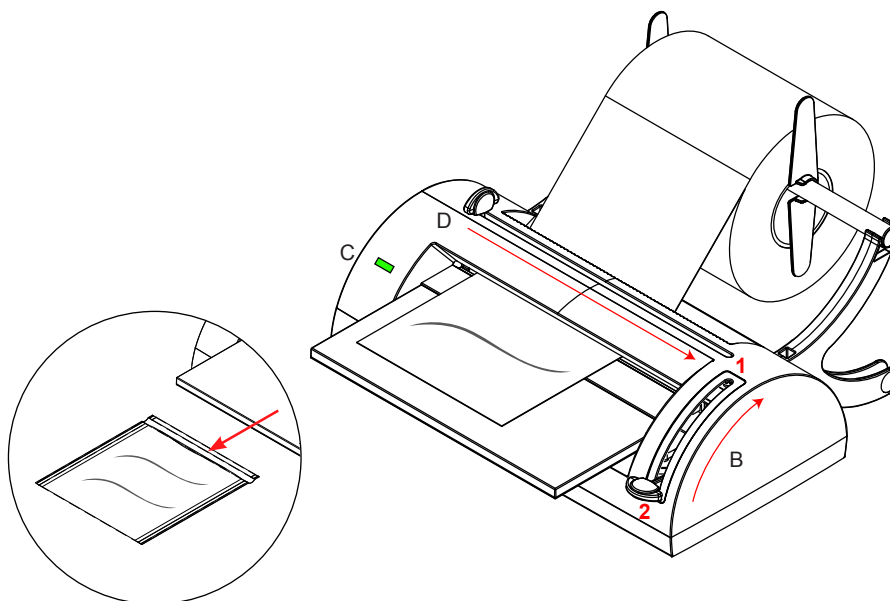

| | |
|--|--|
| | <p>NOTE</p> <p>IF THE LEVER DOES NOT LIFT AFTER A FIRST ACOUSTIC SIGNAL, THE SEALING MACHINE WILL EMIT ANOTHER TONE AND THE LED WILL FLASH RED.</p> |
|--|--|

| | |
|--|---|
| | <p>DANGER</p> <p>DO NOT PUT FINGERS IN THE WELDING AREA WHEN THE MACHINE IS ON AND IMMEDIATELY AFTER IT HAS BEEN SWITCHED OFF.</p> |
|--|---|

| | |
|--|---|
| | <p>DANGER</p> <p>DO NOT PUT FINGERS IN THE CUTTING LEVER SLOT.</p> |
|--|---|

| | |
|--|---|
| | <p>DANGER</p> <p>DO NOT LEAVE PAPER INSERTED IN THE SEALING AREA WHEN THE MACHINE IS NOT IN USE.</p> |
|--|---|

5.4. BAG RETURN AND FINISHING

- Insert the instruments in the open side of the bag, following the warnings contained in the chapter "Material preparation" (see following page).
- Insert the unwelded end of the bag in the front slot (F) a few centimetres, until the end of the bag is aligned with the upper slot (G).
- Perform sealing operations as previously described.

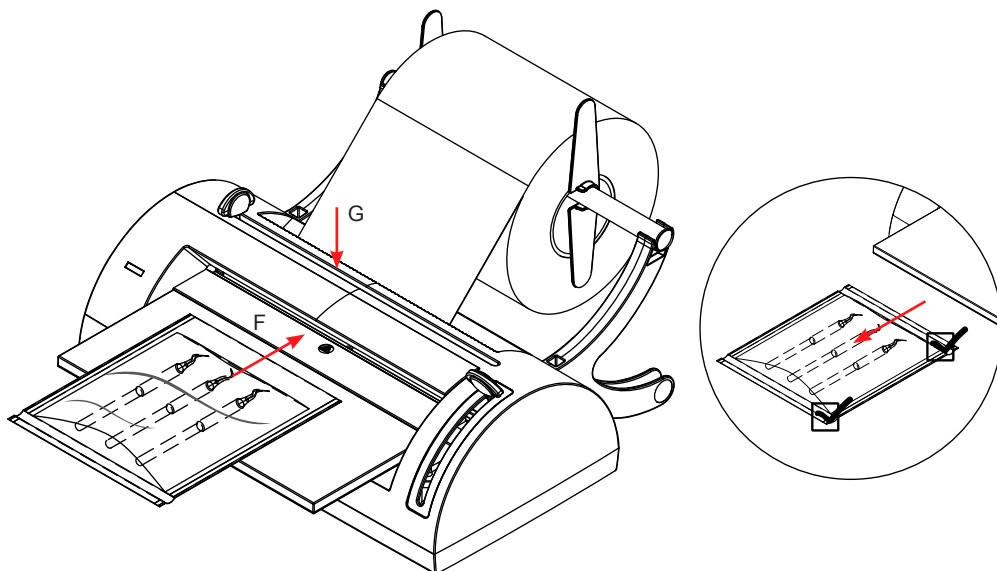

NOTE

AFTER A PERIOD OF INACTIVITY OF 30 MINUTES, THE MACHINE WILL GO INTO STAND-BY MODE, SWITCHING OFF THE HEATING RESISTANCE. STAND-BY STATUS IS SIGNALLLED BY PERIODIC DOUBLE-FLASHING OF THE GREEN LED.

TO RESET MACHINE OPERATION, LOWER AND LIFT BACK UP THE WELDING LEVER. THE MACHINE WILL REACTIVATE THE HEATING RESISTANCE (FLASHING GREEN LED) WAIT FOR THE MACHINE TO HAVE REACHED THE IDEAL TEMPERATURE ONCE AGAIN (FIXED GREEN LED) BEFORE STARTING USE AGAIN.



6. PREPARING THE MATERIAL TO BE SEALED

The sterilization process can be considered as effective, reliable and repeatable on condition that the instruments and the materials in general are first properly treated and subsequently correctly positioned inside the sterilization chamber.

This foresight is even more required when we consider objects within an envelope.

It must be stressed that organic residue or deposit of substances used in the medical practice inevitably become receptacle of micro-organisms and can hamper the steam sterilization process.

An improper arrangement of the load makes difficult and sometimes impossible the circulation of water steam on the material and/or inside its cavities, with the consequences that can be imagined.

Therefore we provide a few basic indications concerning these aspects, leaving the customers with the task of improving their knowledge on the matter in the best fashion.

6.1. MOVING THE MATERIAL

When handling and moving contaminated material, it is good practice to take the following precautions:

- Always wear rubber gloves with adequate thickness;
- Clean with a germicide detergent the hands protected with the gloves;
- Always use a tray for carrying the tools.
- Never carry the tools directly in your hands;
- Pay attention to any sharp or cutting parts to avoid the risk of infections;
- Separate the objects that must not undergo a sterilization or cannot stand the process;
- When you have finished handling the material, carefully wash your hands still gloved.

6.2. CLEANING THE TOOLS

All materials and/or tools to be sterilized must be perfectly cleaned and without trace of any kind of residue (organic and inorganic materials, paper fragments, cotton or gauze swabs, scale, etc.).

Otherwise, the sterilization process could turn out to be not effective, and the sterilizer and the tools themselves undergo irreversible damage.

For an effective cleaning:

- After use, immediately rinse the tools with a jet of running water;
- Divide the tools according to the type of material (carbon steel, stainless steel, brass, aluminium, chrome etc.) to avoid processes of electrolytic oxidation-reduction;
- Carry out a washing with an ultrasonic cleaner containing a mix of water and germicide solution, carefully following the manufacturer's recommendations.
- Carefully rinse and check that the cleaning is complete; if necessary repeat the washing cycle or clean manually.
- Dry perfectly.

Before the sterilization, check the indications provided by the manufacturer of the tool/ material, checking any incompatibility.

Meticulously follow the use procedures for detergent or disinfectant products and the instructions for the washing and automatic lubrication equipment.

6.3. WRAPPED MATERIAL

The use of sterilization paper envelopes allows both an optimal sterilization and to maintain in time the sterility condition.

Follow these general indications:

- Envelope the tools one by one or make sure that they are made of the same material;
- Close the envelope with the thermo-sealer.
- Do not use metal points, pins or similar since they do not warrant sterility;
- Arrange the envelopes so as to avoid the creation of air pockets that prevent the correct penetration and the removal of the steam.
- If possible, arrange the envelopes vertically using a suitable support.
- Never overlap the envelopes one over the other.

APPENDIX A TECHNICAL CHARACTERISTICS

SUMMARY TABLE

| Device | Thermo-sealer |
|---|--|
| Model | MILLSEAL PLUS |
| Manufacturer | CEFLA s.c. Headquarters Via Selice Provinciale 23/A – 40026 Imola (BO) |
| Power supply voltage | 220-240 V~ |
| Frequency | 50-60 Hz |
| Mains fuses (5 x 20 mm) | T 3,15 A - 250V |
| Nominal power | 150 W |
| Insulation class (IEC 61010-1) | Class I |
| Installation category (IEC 61010-1) | Cat. II |
| Utilization | Internal use |
| Operating environment conditions | Temperature: +15°C ÷ +35°C |
| | Relative humidity: 80% (max), without condensation |
| External dimensions (without roll) (L x D x H) | 474 x 374 x 200 mm |
| Net weight | 5 kg |
| Type of sealing | With continuous cycle and constant temperature |
| Nominal operating temperature of the heating resistance | 180°C |
| Max sealing length | 12 mm |
| Maximum welding width | 300 mm |
| Sealable material | Paper /polypropylene fil |
| Max diameter of the roll | 200 mm |
| Maximum roll width | 300 mm |
| Orientation of the paper /polypropylene fil | Polypropylene film oriented upwar |

The data plate is placed back on the unit.

SAFETY DEVICES

The thermo-sealer is equipped with the following safety devices, of which we list a short description along with their function:

- **Mains fuses** (see data in the above table)
Equipment protection from internal electrical faults.
Action: break the electrical power supply.
- **Automatic off of the heating circuit**
If the lever is not lifted back up after sealing has been completed, the heating circuit will be automatically deactivated. This operation will be indicated by an acoustic signal and intermittent red LEDs.
- **Anti- finger crushing design**
Protection from accidental crushing of fingers during lever movement
- **Automatic Stand-By System.**
After a period of inactivity of 30 minutes, the machine will go into stand-by mode, switching off the heating resistance.
This device protects from risks of overheating caused by a failure to switch off the machine at the end of use, creating significant energy conservation at the same time
- **Protected cutting knife**
Exclusive design with cutting knife totally inaccessible from outside.

APPENDIX C - MAINTENANCE

GENERALS

The equipment does not need any special care; it is only recommended that the user cleans it periodically.

In all cases carefully follow the procedure detailed below.

In case of replacement of equipment components, request and use ONLY ORIGINAL SPARE PARTS.



DANGER
BEFORE PERFORMING ANY MAINTENANCE OPERATION, DISCONNECT THE PLUG OF THE POWER SUPPLY CABLE FROM THE SOCKET.



ATTENTION
MAKE SURE THAT THE MACHINE HAS COOLED BEFORE ANY MAINTENANCE OPERATION.

CLEANING

Clean the equipment externally with a clean cloth dampened with water and neuter detergent.



NOTE
- DO NOT USE PRODUCTS CONTAINING ISOPROPYL ALCOHOL (2-PROPANOL, ISO-PROPANOL).
- DO NOT USE PRODUCTS THAT CONTAIN SODIUM HYPOCHLORITE (BLEACH).
- DO NOT USE CLEANERS THAT CONTAIN PHENOL

Perfectly dry the surfaces and remove any remaining resistant residue.

Always keep in mind the following general warnings:

- Do not submit the unit to direct water jets, under pressure or sprinkling. Any infiltration on the internal electrical components could irretrievably damage its operation;
- Do not use abrasive sponges, metal brushes (or other aggressive materials) or products for cleaning of metal, both solid and liquid.

BLADES REPLACEMENT

The blade must be replaced periodically or when paper cutting problems are noticed. Contact technical support.

FUSES REPLACEMENT

The fuses are in the fuse holder above the power lead outlet.

- Remove the power lead plug.
- Remove the fuse holder box with a screwdriver.
- Replace the fuse with one of equal value (see appendix A).

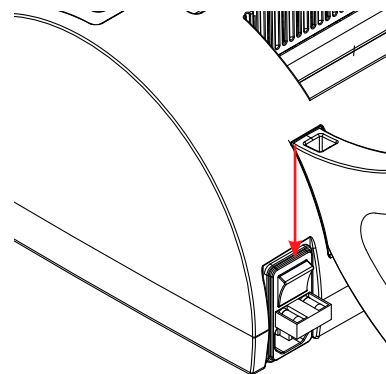

DISPOSAL AT END-OF-LIFE

In accordance with Directive 2012/19/UE, regarding the reduction in use of dangerous substances in electrical and electronic equipment, as well as waste disposal, such equipment may not be disposed of as normal urban waste and must be separated accordingly. When purchasing a new, equivalent piece of equipment, the old piece of equipment that has reached its end-of-life must be handed over to the reseller for proper disposal. The Manufacturer will carry out the functions defined by individual national legislation with respect to the reuse, recycling and other forms of salvaging of the above-mentioned waste. The proper collection and separation of such equipment for recycling, treatment and disposal helps avoid any possible negative effects on the environment and health and facilitates the recycling of the materials of which the equipment is made. The crossed out rubbish can symbol indicates that the product, at the end-of-life, must be collected separately from other types of waste.



WARNING!
IMPROPER DISPOSAL OF THE PRODUCT RESULTS IN THE APPLICATION OF SANCTIONS WHICH ARE DEFINED BY INDIVIDUAL NATIONAL LAWS.

APPENDIX D - TROUBLESHOOTING

If Your Thermo-sealer does not work correctly, carry out the following checks before contacting the Technical Service:

| PROBLEM | POSSIBLE CAUSE | SUGGESTED SOLUTION |
|--|--|--|
| The thermo-sealer does not switch on. | The plug of the power supply cable is not inserted in the outlet. | Properly put in the plug. |
| | Lack of power at the power supply outlet. | Check the possible cause of power failure and try to solve it. |
| | The magneto thermal switch and/or differential switch of the installation are OFF. | Put the switches to ON position. |
| | Mains fuses broken | Replace the fuses (see Appendix C - Maintenance) |
| The LED does not flash when the thermo-sealing machine is switched on | The Led does not work. | Contact the Technical Support Service |
| | Heating resistance broken. | |
| | Fault in the electronic card. | |
| Bag sealing is performed but the LED remains a fixed green (instead of red) and no acoustic signals are heard. | Fault of the end-of-run microswitch. | Contact the Technical Support Service |
| | Insufficient pressure in the sealing area | Contact the Technical Support Service |
| | Silicon rubber profile damaged | |
| | Resistance does not reach the operating temperature | |
| Envelope cutting is difficult | Consumed blades. | Contact the Technical Support Service |



NOTE:

SHOULD THE PROBLEM PERSIST, PLEASE CONTACT OUR TECHNICAL SERVICE NETWORK REPORTING THE THERMO-SEALER MODEL AND ITS SERIAL NUMBER.

THESE DATA CAN BE FOUND ON THE FACTORY PLATE PLACES ON THE UNIT REAR.

Operator warning signal

| SIGNAL | CAUSE | ACTION |
|---|--|--|
| The LED is flashing gree | The machine is warming up | Wait until the machine warms up. |
| The LED is steady green | The machine is ready for use | - |
| The LED is fast flashing gree | The sealing lever has been lowered and the machine is in use | Wait for the acoustic signal, lift the lever and remove the bag |
| The green LED emits a brief flash every 5 seconds | The machine is in a paused status after a period of inactivity of 30 minutes. | Lower and lift back up the lever to rest normal operation. |
| The red and green LEDs flash at the same tim | The machine signals the presence of a heating system problem. | Switch off and retry machine use. If the signal recurs, contact Technical Support. |
| The LED is solid red and the machine is emitting an acoustic signal | The sealing operation has been completed | Lift the lever and remove the bag |
| | The machine is on with the sealing lever down | Lift the lever |
| | The sealing lever was lowered before reaching the proper operating temperature | |